

Staff Report

TO: Board of Directors

FROM: Chip Close, Director of Water Operations
Aurora Tipton, Customer Service Administrator

DATE: November 9, 2022

SUBJECT: Residential Fire Sprinkler Connection Changes (Consent)

WATER OPERATIONS

RECOMMENDATION:

Approve changes to NID's Water Service Regulations and Standard Detail 13 regarding new residential fire sprinkler connections as recommended at the Board Workshop on October 26, 2022.

BACKGROUND:

On October 26, 2022, the Board reviewed and discussed changes to the District's Water Service Regulations and Standard Detail 13; changing new residential fire sprinkler connections to a 1-inch meter standard.

The change will replace the current double meter approach utilized by NID since the residential fire code in 2016 required sprinklers on all new construction. While the double meter approach met the needs of the local building ordinances, it is not efficient or cost effective for NID or its customers. Each connection doubles the amount of infrastructure NID must install, monitor, maintain, and bill. In addition, the monthly fee for smart meter data service is doubled; a cost that is passed along to customers.

In an effort to increase efficiencies and reduce customer and NID costs, Staff is recommending a change to a single 1" meter installation when a residential fire sprinkler system is necessary. Staff's investigation of other available options found the single meter approach to be the standard amongst other local agencies (PCWA, EID).

The proposed change will standardize new residential connections required to install fire sprinkler systems to a single 1-inch meter. The capacity provided by a 1" meter will suffice for fire flow needs, yet is oversized for general consumptive needs. NID's average consumptive capacity for residential connections is a standard 5/8-inch meter capacity (1,250 GPD). Staff is recommending the average be applied to these connections as the larger meter is only for fire purposes. Customers requesting consumptive demands larger than a 5/8-inch meter will pay capacity fees based upon the requested meter size as established in Fee Schedule 4-A.

Staff is recommending this change be implemented for all new connections requiring residential fire sprinkler systems. Existing dual meter installations will remain in place until there is a need for maintenance on the existing meters (leak or meter change out), or due to a customer request in a change of meter size. The conversion of a dual meter set up to the 1" standard will be performed by NID at no cost to the customer, and the work will be warrantied for 1 year.

BUDGETARY IMPACT:

The proposed changes should have no substantial impact to the budget, however, a reduction in staff time and customer fees should be realized with the new standard.

Attachments (5):

- NID Water Service Regulations
Section 4.06.03 through 4.06.05 Red Lined
- Schedule 4A Red Lined
- Schedule 4EI/4EO Red Lined
- Schedule 8C Red Lined
- Standard Detail 13

rev. 01/26/05

4.04.03 Capacity Charge

The capacity charge represents the customer's share of capital costs associated with the District's treated water system. Cost components are included for the treatment plant, storage tank and transmission pipelines and are based on the anticipated capacity requirements of a water service. These charges are non-refundable if service is terminated at a later date.

Capacity charges are shown in Schedule 4-A; however, in the case of water services covered by conveyance agreements or water development agreements, special capacity charges may be indicated. All water development agreements based on Board Resolution 74-55 provide for no capacity charge for a minimum size water service since the original developer had paid these charges, or installed the necessary water system improvements as part of the development. (The term "water development agreement" is no longer utilized in writing agreements.)

The standard capacity charge for residential connections is assessed based on the meter size. In some cases, local ordinances may require increased flow for residential fire sprinklers. Residential connections requiring upsize based solely upon fire sprinkler needs will be assessed a 5/8-inch capacity charge. Residential connections requesting meters larger than the standard 5/8-inch, not required for fire sprinklers, shall be assessed capacity charges based upon the meter size selected and installed as shown in Schedule 4A.

rev. [11/09/22](#)

4.05 WATER PRESSURE

4.05.01 Variations of Water Pressure

Due to the foothill terrain predominating District treated water service areas, large variations of pressure can occur along a short stretch of any water main. Under normal conditions, the District attempts to maintain a minimum pressure of 20 pounds per square inch (psi) at its water main. It is the customer's responsibility to provide adequate size service lines on the customer side of the

meter assembly, as well as any pumping facilities needed to compensate for water pressure losses between the meter assembly to the point of water use.

4.05.02 Low Pressure

If the District determines that a new service point would provide a normal pressure of less than 20 psi at the District's water main, the customer will be informed of the low pressure situation at the time of application. The customer will be required to acknowledge in writing that a notification was received prior to District approval of the application.

4.05.03 High Pressure

If the District determines that a new service point may provide pressure in excess of 80 psi at the District's water main, the customer will be notified of the high pressure at the time of application and that the installation of a pressure-reducing valve, along with a pressure relief valve, may be advisable. The customer will be responsible for installation and maintenance of the valves.

The District will provide the installation of a pressure-reducing valve at no cost to the existing customer where actions by the District cause an increase in the normal sustained operating pressure in the water main to exceed 80 psi. Upon installation, the pressure-reducing valve becomes the property and responsibility of the customer.

4.05.04 Excessive Pressure Variations Caused by Customer's Equipment

A customer shall not install any pump, quick closing valve, or other equipment or devices which cause excessive pressure drops or surges in the District's water system. Violation of this regulation will be cause for immediate termination of service. The customer will be liable for all damages to District facilities resulting from the installation of any such equipment.

4.05.05 Water Heaters

Water heater installations should be made in conformity with the applicable plumbing code. In addition, customers with back flow protection devices or pressure reducing valves installed as part of their water service should consult with a professional plumber for advice on thermal expansion safeguards.

The District will not be responsible for the safety of domestic or commercial water heaters, boilers or tanks on the premises of any customer.

eff. 6/11/03

4.06 METER INSTALLATIONS

4.06.01 General

In order to equitably distribute, conserve and limit capacity in the District's water system, all treated water services will be metered in a manner meeting District approval. The District will own and maintain the meter assembly to and including the customer's service valve located on the customer's side of the meter.

4.06.02 Installation

Installation of a 5/8" ~~or~~ 3/4" or 1" meter for parcels with an existing service lateral will be subject to the Drop In rate as established in Schedule 4-A. Locations without an existing service lateral or requiring upsize of the existing service lateral will be charged at the Installation Requiring Tap to Main rate as established in Schedule 4-A. Applicants shall submit a completed Form 4A(1) Request for New Treated Water Service.

Installation of a meter ~~over 3/4", or any fire meter used for residential fire service suppression~~, will require the applicant submit a completed Form 4A(2) Request for New Treated Water Service and Fire Meter, and pay the Water Availability Fee as determined in Schedule 6-A. The District will provide the applicant the pressure, and if applicable, the existing service lateral size. The applicant shall confirm if the existing service lateral is adequate to meet their requirements.

Rev. 06/27/18; 11/09/22

4.06.03 Parcel Requirements

Each parcel of land being served treated water must have at least one meter connection. A meter connection may not be used to serve two or more parcels. An exception to the above is the use of one meter connection to serve a green belt area common to several parcels which contain commercial type development. In this case, the owners of the parcels being served must either

form an association or assign a trustee who is responsible for the upkeep of the common area and responsible for paying water use charges. Each of the parcels involved in the green belt area must have its own meter connection for water uses other than service to the green belt area.

In certain instances the District, at its sole discretion, may permit a single parcel to have more than one meter connection. Examples include a shopping center with varied tenant water requirements or two residences located on one parcel. The District may require parallel meter assemblies with downstream valved interties for certain customers who are sensitive to water outages caused by periodic maintenance or testing of the meter assembly.

4.06.04 Extent of Service Through Meter

The District provides metered service by using two different concepts, individual meters and master meters.

Individual meters are used for residential, commercial, commercial/production agriculture, industrial parcels and lots as well as townhomes, residential condominiums and mobile home subdivision lots. In general, individual meters are placed along the street frontage of each parcel at lot corners. In the case of individually metered condominiums and townhomes, the meters are placed in the general vicinity of each cluster of units in a manner acceptable to the District and the onsite waterlines leading to the meter complexes are conveyed to the District for ownership. Separate meters are required for green belt and common use areas in these types of developments.

Master meters are used for apartment buildings, mobile home parks, motels, hotels, campgrounds, hospitals, skilled nursing facilities and board and care facilities. Master meters are generally placed along the project's frontage near the District's water main in a manner meeting District approval. In certain instances, the District may require conveyance and ownership of water mains located inside the project in order to properly serve areas lying beyond the project or to provide for future looping of the District's water distribution system. In these cases, master meters may be placed along the interior of the project in the general vicinity of the main building clusters in a manner meeting District approval.

Condominiums developed for office, professional, commercial, or industrial uses may be metered individually or by a master meter at the discretion of the owner. If a master meter is selected, an association or trustee must be assigned the responsibility for paying all water use charges.

Parcels involved with commercial/production agriculture use must have its own dedicated meter connection for irrigation use separate from the domestic use meter. Each meter is subject to all applicable connection and capacity fees. The irrigation and domestic meter shall be subject to backflow requirements as set forth in Section 9 of these regulations.

rev. 08/09/17

The metering concepts discussed above shall also apply to the conversions of existing buildings. As an example, conversions of a building to residential condominiums will require a meter for each unit.

From time to time, new state and county statutes may be adopted allowing for new types of developments. The metering concept to be used, either master meter or individual meters, in cases of types of developments not specifically discussed in these Regulations, will be determined by the District on a case-by-case basis.

eff. 6/11/03

4.06.05 Sizing

The customer will make the basic determination as to the size of meter required; however, the District reserves the right to approve the size of service allowed.

Services to individual homes are normally limited to 5/8-inch or 3/4-inch size, however many new residences are required by local ordinance to have a larger meter in order to provide sufficient flow for residential fire sprinklers. For connections where a residential fire sprinkler system is required a 1 inch meter will be installed. Residential fire systems requiring a meter larger than 1-inch will require consultation with the District.

rev. 11/09/22

**TREATED WATER SYSTEM
 STANDBY CHARGES AND CONNECTION FEES**

STANDBY CHARGES²: \$6.00 per month per parcel

CONNECTION FEES^{3,4}, Non-Commercial⁴ use

Drop In (Existing Meter Box and Water Service Lateral)

Simple Drop In		-----Capacity Charge-----	
Meter Size	Installation Charge	Parcels In District Prior to 03/01/2007	Parcels Annexed to District After 03/01/2007
5/8"	445.20	\$ 11,985.00	\$ 16,073.00
3/4"	468.70	17,258.00	23,146.00
<u>1"</u>	<u>511.20</u>	<u>30,683.00</u>	<u>41,043.00</u>
Complex Drop In, Domestic Meter & Fire Meter Installation Residential Requiring Fire Sprinklers			
5/8" & 1"	\$2,052.30 <u>511.20</u>	\$ 11,985.00	\$ 16,073.00
3/4" & >Over	1" <u>-2,075.80</u>	<u>Determined by District</u> 17,258.00	<u>23,146.00</u>

Installation Requiring Tap to Main*

		-----Capacity Charge-----	
Meter Size	Installation Charge	Parcels In District Prior to 03/01/2007	Parcels Annexed to District After 03/01/2007
5/8"	\$ 7,562.60	\$ 11,985.00	\$ 16,073.00
3/4"	7,586.20	17,258.00	23,146.00
1"	7,628.70	30,683.00	41,043.00
1 1/2"	7,843.60	69,021.00	92,910.00
2"	8,013.30	122,725.00	164,599.00
Over 2"	DETERMINED BY DISTRICT		
Domestic Meter & Fire Meter Installation Residential Requiring Fire Sprinklers			
5/8" & 1"	\$ 8,031.90 <u>7628.70</u>	\$ 11,985.00	\$ 16,073.00
3/4" & Over	1" <u>8,055.50</u>	<u>Determined by District</u> 17,258.00	<u>23,146.00</u>

***Service Lateral Installation Cost**

\$108.00 per foot of service lateral installed per standard detail
 (in addition to meter installation cost)

NOTE: Add 25% to all charges above for existing accounts serving lands outside the District (amount rounded to the nearest dollar.) The District does not presently offer treated water service to new accounts serving lands outside the District.

¹BOD 01/25/2017; 09/13/2017; 06/27/2018; 12/08/2021

² BOD 12/12/1990, 12/09/1993; Rules & Regulations Section 4.02.01

³ Rules & Regulations Section 4.04

⁴ Rules & Regulations Section 4.01.04

**TREATED WATER SYSTEM
STANDBY CHARGES AND CONNECTION FEES (CONTINUED)**

CONNECTION FEES: Commercial, Industrial, Municipal and Multi-Unit Master Meters⁵

Meter Size	-----Installation Charge-----		Capacity Charge
	Simple Drop-In (Existing Meter Box and Water Service Lateral)	Installation Requiring Tap to Main*	
5/8"	\$445.20	\$ 7,562.60	Requires Water Demand Analysis - See Below
3/4"	468.70	7,586.20	
1"	511.20	7,628.70	
1 1/2"	726.20	7,843.60	
2"	895.90	8,013.30	
Over 2"	DETERMINED BY DISTRICT		
Complex Drop In, Domestic Meter & Fire Meter Installation			
5/8" & 1"	\$ 2,052.30	\$ 8,031.90	Requires Water Demand Analysis - See Below
3/4" & ≥ 1"	2,075.80	<u>Determined By District</u> 8,055.50	

***Service Line Installation Cost**

\$108.00 per foot of service line installed per standard detail (in addition to meter installation cost)

Capacity Charge

Fees will be based on an engineering analysis of expected peak day water capacity provided by the developer's engineer. The District will review the report for acceptance. If accepted, the District will utilize the report to calculate fees based on the peak capacity in Equivalent Residential Units (5/8 inch meter). The 2014 Adopted Capacity Fee Study indicates a peak day capacity of 1,250 GPD per 5/8 inch meter or equivalent (p. 12).

An example of calculation is as following:

Approved Meter Capacity by developers engineer: 6250 GPD
 Equivalent ERU Calculation: $6250 \text{ GPD} / 1250 \text{ gal per ERU} = 5 \text{ ERU}$
 Capacity Fee Calculation: $5 \text{ ERU} \times \$11,985 / \text{ERU} = \$59,925 \text{ for capacity fees}$

NOTE:

Add 25% to all charges above for existing accounts serving lands outside the District (amount rounded to the nearest dollar.) The District does not presently offer treated water service to new accounts serving lands outside the District.

⁵ Rules & Regulations Section 4.01.03

SCHEDULE OF RATES AND CHARGES
 BY NEVADA IRRIGATION DISTRICT

SCHEDULE 4-EI & 4-FI¹
 EFFECTIVE ~~JANUARY 01, 2021~~ NOVEMBER 09, 2022

NONCOMMERCIAL / COMMERCIAL, INSIDE DISTRICT

Charges for treated water delivered through a metered connection utilized inside District.

Service Size:	5/8" ¹	3/4"	1"	1 1/2"	2"	3"	4"	6"	8"
Monthly Fixed Service Charge:	29.33	44.00	73.34	146.67	234.68	469.35	733.36	1,466.72	2,346.75

¹ When a 1" meter is required solely to meet fire suppression requirements, the 5/8" monthly fixed service charge shall be assessed.

Volumetric Service Charge: (\$ per hundred cubic feet (hcf) per billing period)		
First	5 HCF per billing period	2.42 per HCF
Over	5 HCF per billing period	3.13 per HCF

Volumetric Service Charge During a Drought Declaration:				
(\$ per hundred cubic feet (hcf) per billing period)				
Drought Stage*:		2	3	4
First	5 HCF per billing period	2.99 per HCF	3.71 per HCF	4.93 per HCF
Over	5 HCF per billing period	3.87 per HCF	4.80 per HCF	6.37 per HCF

* Per the Nevada Irrigation District Drought Contingency Plan

State & County Mandated Fee \$1.90

¹ Board Resolution 2019-06

SCHEDULE OF RATES AND CHARGES
 BY NEVADA IRRIGATION DISTRICT

SCHEDULE 4-EO & 4-FO²
 EFFECTIVE ~~JANUARY 01, 2021~~ NOVEMBER 09, 2022

NONCOMMERCIAL / COMMERCIAL, OUTSIDE DISTRICT

Charges for treated water delivered through a metered connection utilized outside District.

Service Size:	5/8"¹	3/4"	1"	1 1/2"	2"	3"	4"	6"	8"
Monthly Fixed Service Charge:	36.67	55.00	91.67	183.34	293.34	586.69	916.70	1,833.40	2,933.44

¹ When a 1" meter is required solely to meet fire suppression requirements, the 5/8" monthly fixed service charge shall be assessed.

Volumetric Service Charge: (\$ per hundred cubic feet (hcf) per billing period)		
First	5 HCF per billing period	3.03 per HCF
Over	5 HCF per billing period	3.91 per HCF

Volumetric Service Charge During a Drought Declaration:				
(\$ per hundred cubic feet (hcf) per billing period)				
Drought Stage*:		2	3	4
First	5 HCF per billing period	3.74 per HCF	4.64 per HCF	6.16 per HCF
Over	5 HCF per billing period	4.84 per HCF	6.00 per HCF	7.96 per HCF

* Per the Nevada Irrigation District Drought Contingency Plan

State & County Mandated Fee \$1.90

² Board Resolution 2019-06

MONTHLY OFF RATE CHARGES, TREATED WATER SYSTEM

NON-COMMERCIAL & COMMERCIAL – INSIDE DISTRICT

RATE SCHEDULE	METER SIZE	OFF RATE
1	5/8" ¹	\$ 22.00
2	3/4"	33.00
3	1"	55.01
4	1 1/2"	110.00
5	2"	176.01
6	3"	352.01
7	4"	550.02
8	6"	1,100.04
9	8"	1,760.06

¹ When a 1" meter is required solely to meet fire suppression requirements, the 5/8" monthly fixed service charge shall be assessed.

State & County Mandated Fee \$1.90

NON-COMMERCIAL & COMMERCIAL – OUTSIDE DISTRICT

RATE SCHEDULE	METER SIZE	OFF RATE
1	5/8"	\$ 27.50
2	3/4"	41.25
3	1"	68.75
4	1 1/2"	137.51
5	2"	220.01
6	3"	440.02
7	4"	687.53
8	6"	1,375.05
9	8"	2,200.08

State & County Mandated Fee \$1.90

³ Rules & Regulations Section 4.09

PRIVATE FIRE SERVICE - MONTHLY CHARGES

SIZE	INSIDE DISTRICT DETECTOR CHECK¹	OUTSIDE DISTRICT DETECTOR CHECK²
1" ³	\$ 3.60	\$ 4.50
4"	35.90	44.90
6"	38.60	48.30
8"	44.00	55.00

¹ Usage is charged at double the prevailing 4EI rate schedule.

² Usage is charged at double the prevailing 4EO rate schedule.

³ Applies to dedicated 1" private fire services only

PRIVATE FIRE SERVICE - MONTHLY CHARGES

SIZE	INSIDE DISTRICT DOUBLE DETECTOR CHECK¹	OUTSIDE DISTRICT DOUBLE DETECTOR CHECK²
2", 3" or 4"	\$ 54.30	\$ 67.90
6"	57.00	71.30
8"	62.40	78.00
10"	78.20	97.80

¹ Usage is charged at double the prevailing 4EI rate schedule.

² Usage is charged at double the prevailing 4EO rate schedule.

¹ BOD 12/08/2021; Rules and Regulations Section 8.05.04

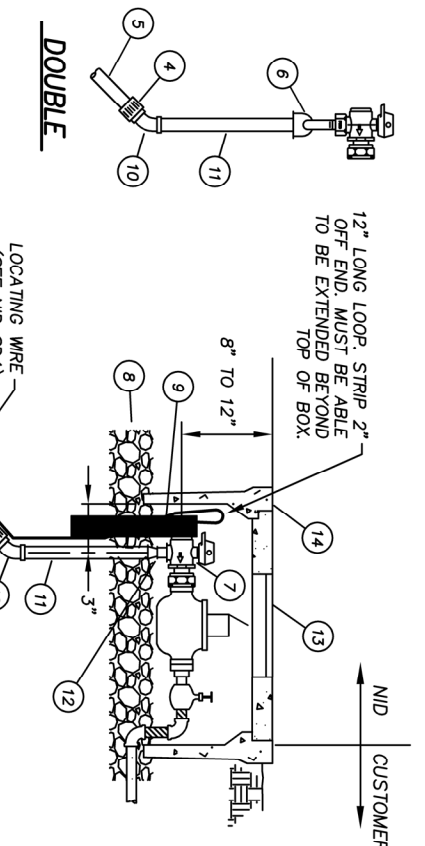
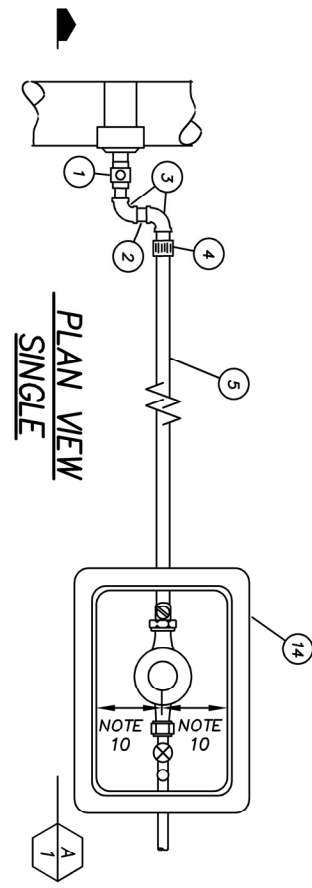
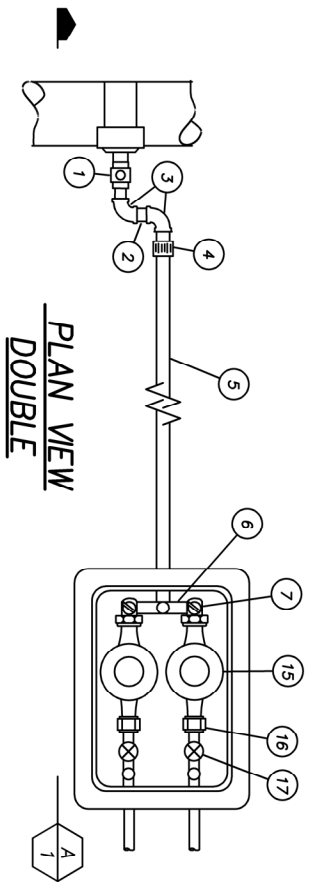

1" METER ASSEMBLIES		SINGLE		DOUBLE	
NO.	DESCRIPTION	SIZE	FORD CAT. NO.	SIZE	FORD CAT. NO.
1.	CORPORATION STOP - MIP x MIP	1.50	FB500-6	1.50	FB500-6
2.	BRASS NIPPLE THD.	1.50		1.50	
3.	BRASS ELBOW	1.50		1.50	
4.	MIP x IPS PE PACK JOINT w/ STIFFENER	1.50	C86-66-IDR7	1.50	C86-66-IDR7
5.	PC200 (IDR7) POLYETHYLENE PIPE PE4710 (ONE PIECE)	1.50		1.50	
6.	1 1/2" FIP x TWO (2) 1" MIP "U" BRANCH w/ 9" SPACING	NA		1.5x1	U18-64-9-NL
7.	ANGLE BALL VALVE (FIP x METER SWIVEL NUT) 1/2	1.00	BA13-444W-NL	1.00	BA13-444W-NL
8.	6" COMPACTED AGG BASE				
9.	TEMPORARY 2x4 STAKE FOR VERTICAL AND SPACING				
10.	BRASS 45° ELBOW (SWIVEL JOINT ALSO ACCEPTABLE)	1.50		1.50	
11.	BRASS SPOOL	1.50		1.50	
12.	1 1/2" x 1" BELL REDUCER AND 1" CLOSE NIPPLE				
13.	CHRISTY LID, FIBRELYTE W PROBE HOLE OPTION - 38 LB	FL36P		FL36P	
14.	CHRISTY METER BOX	B36		B36	2/
15.	1" BADGER METER, N10-0860.0	1.00		1.00	
16.	1" METER COUPLING, N10-0630.0, SPM 3R - 1"x2.625"	1.00		1.00	
17.	1" GATE VALVE	1.00		1.00	

1/ SET METER VALVES PARALLEL TO METER BOX CENTERLINE.
 2/ SET BOX SO THAT LONG DIMENSION OF READING LID SETS PERPENDICULAR TO METERS.

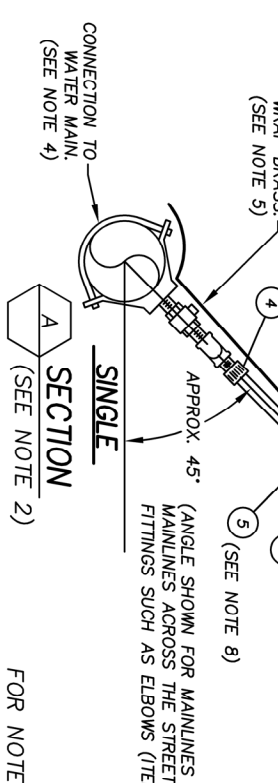

FOR NOTES SEE SHEET 2 of 2

	1" METER FOR FIRE SERVICE SINGLE & DOUBLE	DRAWING NO. SD13 SH1 1 of 2

NOT TO SCALE

NOTES:

1. ALL MATERIALS AND INSTALLATION SHALL CONFORM TO "SERVICE ASSEMBLIES" IN THE SPECIFICATIONS.
2. METER ASSEMBLIES SHOWN ARE FOR NON-TRAFFIC AREAS ONLY. ASSEMBLIES LOCATED IN TRAFFIC AREAS SHALL USE BOXES, LIDS, AND SLABS ALL RATED FOR AN H₂O LOADING AND CONFORMING TO THE SPECIFICATIONS AND SHALL BE FLUSH WITH GRADE.
3. THE LOCATION OF METER BOXES SHALL BE SHOWN ON THE PLANS AND PER NID SD11.
4. THE CONNECTION TO THE WATER MAIN SHALL CONFORM TO "WATER MAIN TAPS" IN THE SPECIFICATIONS.
 DI PIPE: ROMAC STYLE 202, FORD STYLE F202 OR APPROVED EQUAL.
 PVC PIPE: ROMAC STYLE 202S OR 202N, FORD STYLE F202 OR FC202, OR APPROVED EQUAL.
5. THE SADDLE, BRASS COUPLINGS, PIPE AND FITTINGS SHALL BE PRIMED AND WRAPPED FOR CORROSION PROTECTION AS DESCRIBED IN THE SPECIFICATIONS.
6. REFER TO DRAWINGS NID SD1 FOR TRENCH DETAILS AND NID SD4 FOR LOCATING WIRE DETAILS.
7. FORD AND CHRISTY CATALOG NUMBERS ARE GIVEN FOR COMPARISON PURPOSES. SUBSTITUTES CONFORMING TO THE SPECIFICATIONS MUST BE APPROVED BY THE DISTRICT ENGINEER.
8. SERVICE LINES SHALL BE ONE CONTINUOUS PIECE OF PIPE. REMNANT PIECES JOINED BY COUPLINGS WILL NOT BE ALLOWED.
9. ALL METER VALVES SHALL BE SUPPLIED WITH LOCKING NUTS.
10. METERS TO BE PARALLEL AND LEVEL RELATIVE TO CENTERLINE OF METER BOX.
11. INSTALLATION OF HIGH PRESSURE SERVICES (HP, >150 PSJ) ARE AT THE DISCRETION OF THE DIRECTOR OF ENGINEERING.
12. SHOULD THE PROPERTY OWNER HAVE A DEDICATED FIRE SYSTEM DOWNSTEAM OF THE NID METER THAT MAY POTENTIALLY IMPACT THE NID TREATED WATER SYSTEM, NID MAY REQUIRE THE INSTALLATION OF A CHECK DEVICE. THE PRESENCE OR FUTURE INSTALLATION OF A PRIVATE FIRE SYSTEM SHALL BE DETERMINED AT TIME OF APPLICATION TO THE DISTRICT FOR NID SERVICE.

1" METER FOR FIRE SERVICE SINGLE & DOUBLE		DRAWING NO. SD13 SHT 2 of 2
 NID	APPROVED: DOUG RODERICK, P.E. DIRECTOR OF ENGINEERING	REVISION DATE 10/04/22